

# CASE STUDY

## Dual Membrane Plant System Audit

LUMINULTRA<sup>®</sup>  
microbial monitoring



# Case Study

## Dual Membrane Plant System Audit

### Background

The Altona Salt Reduction Plant (ASRP) is a dual membrane plant operated by City West Water and located in the western suburbs of Melbourne. It receives tertiary treated effluent from the Altona Wastewater Treatment Plant (ATP) located on the same site. The ASRP has a total capacity of 9 ML/day and the final produced water is for irrigation and industrial uses.



Each year, approximately 2 billion liters of recycled water is supplied to plastics manufacturer Qenos for use in boiler and cooling water systems; 300 million liters to Sanctuary Lakes Golf Club; 200 million liters to Koorringal Golf Club; 5 million liters to Hobsons Bay City Council to irrigate Altona Green Park and 6 million liters for HD Graham Reserve. Produced water is also used for urban streetscape watering and dust suppression.

Key processes include pre-UF strainers, ultrafiltration, cartridge filters, reverse osmosis (2-pass), degasification and chemical systems.

Chemicals used on-site include: sodium hypochlorite used for UF maintenance washes and disinfection for product water streams; SMBS for quenching; sulphuric acid for pH control; antiscalant, caustic soda and HCl for CIP cleans; lime for calcium addition; and biocide for microbial control.

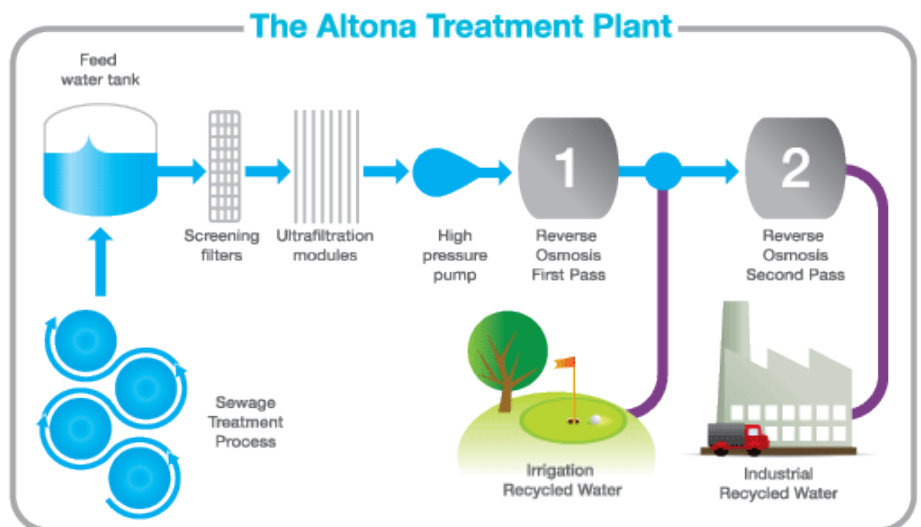

## Test Plan

Current microbial monitoring consists of regulatory culture-based testing of produced water for coliforms and E.coli. Results, however, are only available 2-5 days from sample collection so ATP was investigated as a rapid method for assessing microbiological contamination. A site audit was completed by Arthur Kokolekos of LuminUltra along with Kevin He and Shanli Zhang of City West Water. Six sample points were selected across the ASRP plant to test ATP levels with the QuenchGone Aqueous (QGA) test method: the feedwater tank (SP6), UF outlet (SP5), cartridge filter inlets (SP4), RO1 inlet (SP3), RO1 permeate (SP2), and final produced water (SP1).

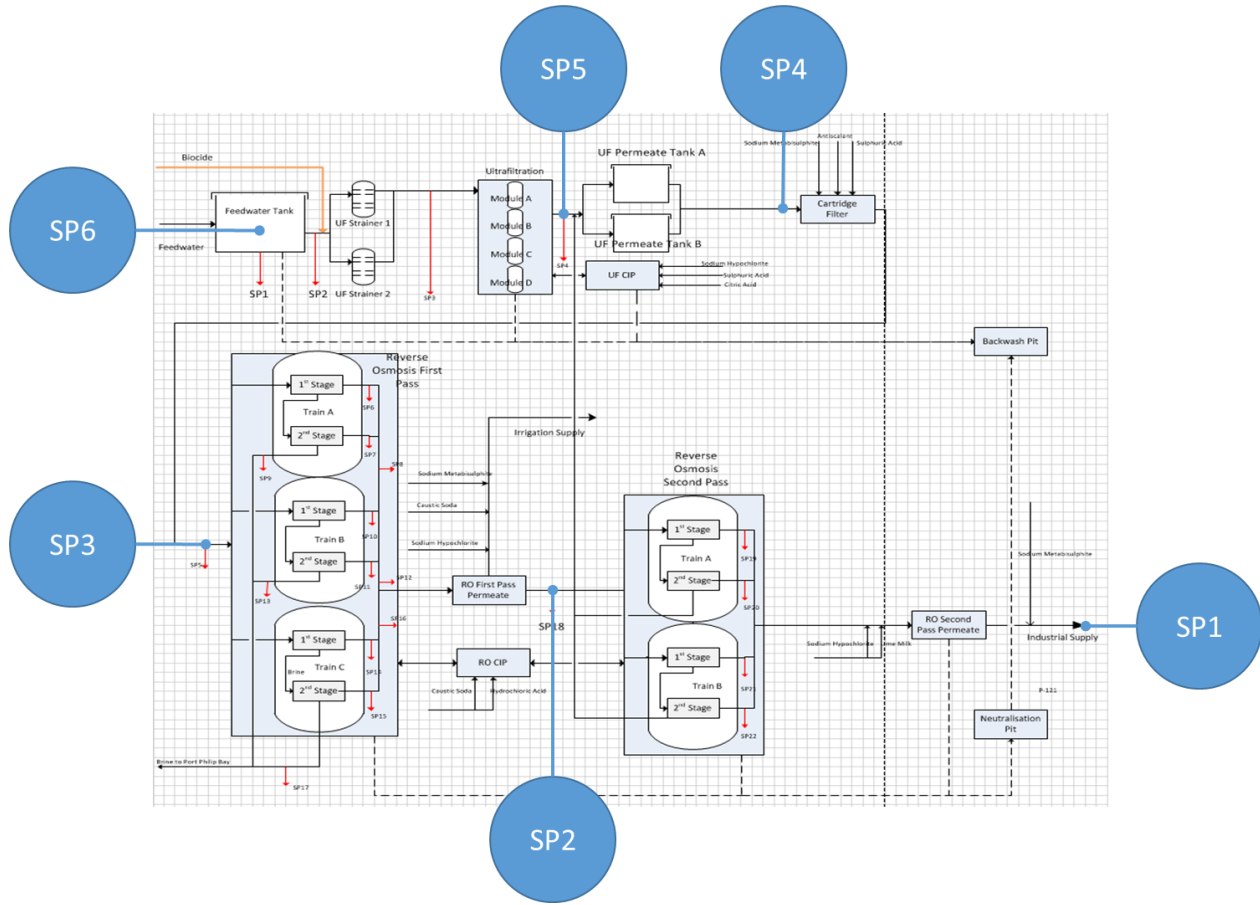

Because plant feedwater is received from the Altona Wastewater Treatment Plant, it is critical that elevated microbiological growth levels be detected quickly and treated effectively to ensure consumer safety and to maintain infrastructure and equipment integrity.

## Results

The QGA test kit and equipment set were taken into the field and tests were completed at each of the six sample points. Control ranges were set as per the recommended guidelines for “water for consumption” which includes potable and sanitary water.



Results were returned within 5 minutes of testing and effective removal of microbiological contamination was seen at each stage of the process with the most significant decrease being through the ultrafiltration system and through the first pass RO system.

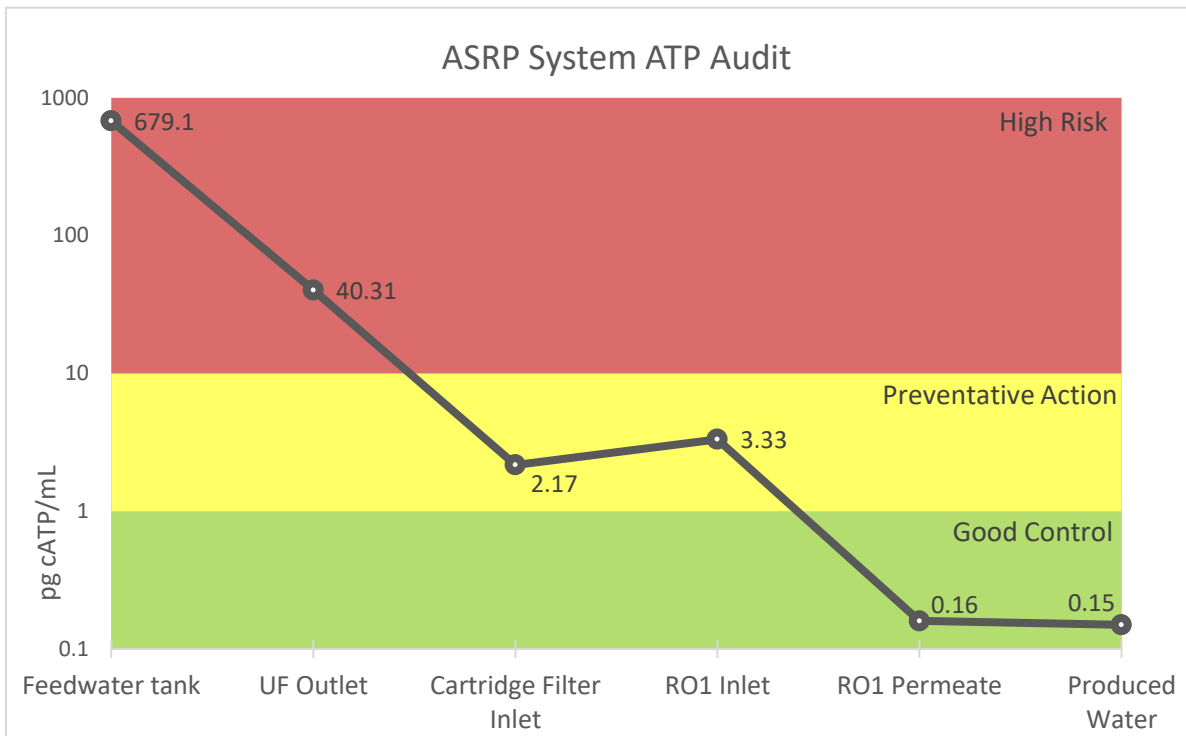

Frequent monitoring allows operators to identify microbiological growth at the earliest stages and can help operators identify biological fouling within the membrane filtration systems. This provides them with the information required to determine optimal cleaning frequencies, select the appropriate treatment to prolong the lifespan of their membranes, equipment and infrastructure, and confirm biological control throughout the system.

## Conclusions

Because a variety of microorganisms can result in water quality issues and infrastructure risks, an immediate measure of total microorganisms is an invaluable first line of defense in the management of water treatment systems. When elevated risk is identified, further action can be taken and efficacy of the corrective action can be confirmed immediately to ensure consistent high quality produced water.

A monitoring program such as this can be easily established for any water system, no matter the size, using LuminUltra's rapid microbiological monitoring technology!